



IronStar®

from HALLEN PRODUCTS

Model 664

Low Profile

**3M™ Snowplowable
Marker Series 190**

A Snowplowable Raised
Pavement Marker
Designed To
Endure The
Rigors Of
The Road.



Designed For Safety. Engineered To Last.





Designed For Safety. Engineered To Last.

Model 664 Low Profile

Snowplowable Systems Or Replacement Units? It's Your Choice.

The IronStar System not only provides high visibility from distances of 1,000 feet or more, but also the low profile base plate with contoured edges and an exclusive cast-in cross-grip design is intended to reduce plow bounce and minimize vertical and horizontal movement.

Low Installation and Maintenance Costs

You can save money with the snowplowable IronStar System because it eliminates multiple depth installation cuts by creating a simple rectangular cavity. And you can reduce epoxy use by changing to recommended blade size (16" dia.-22 blades required), or use your existing blades (18" dia.-22 blades required).

Low Profile Design/ Contoured Edges

Sleek, low profile design hugs the road while smooth, contoured edges are designed to reduce plow bounce. All lead edges of the base casting being sub-surface allows encapsulation by epoxy thus reducing seal break and sledding effect once installed.

Improved Holding Strength

The exclusive IronStar casting design allows approximately twice the amount of epoxy overlay, when properly installed. This results in increased holding strength for a more secure marker.

Replacement Unit

3M™ Snowplowable Marker Series 190



Small Footprint/Single Depth Cuts

Eases installation, saves time and money, and reduces epoxy use.

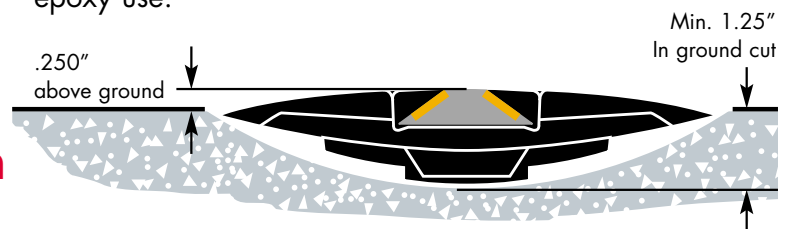

Hallen Products is proud to feature the patented IronStar System—a high visibility raised pavement marker that’s as tough as the road.

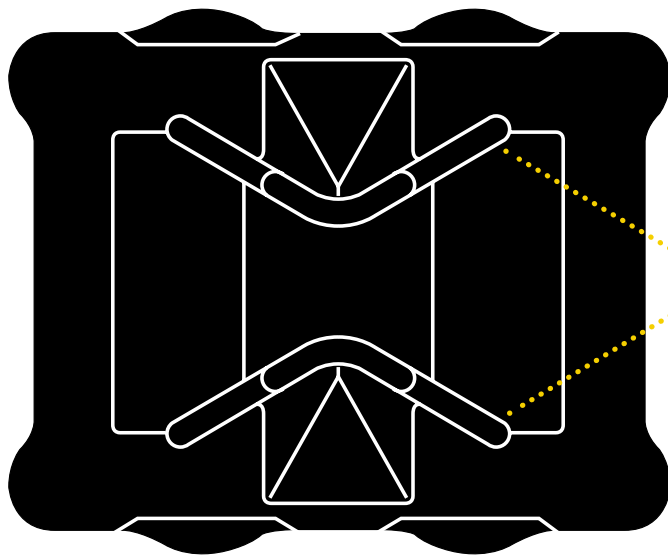
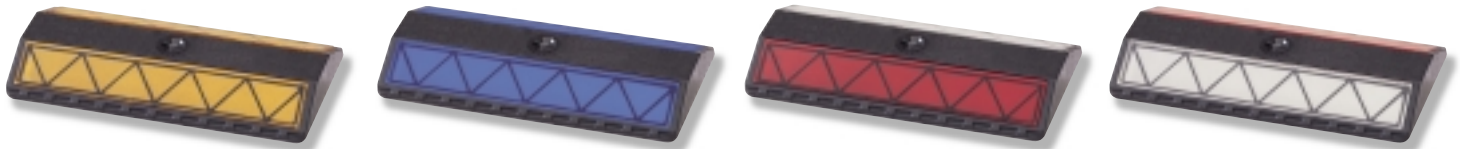

Bottom View

Cast-in cross-grip design minimizes vertical and horizontal movement

Cast-in Cross-Grip Base Design

Helps stabilize marker, minimizes vertical and horizontal movement. The Ironstar exclusive cross-grip system provides a multi-directional resistance across substantially all of the width of the marker. In addition, the pyramidal webs promote even distribution of epoxy from front to back as well as up both sides of the base casting during installation.

Multiple Colors For Multiple Applications

The Hallen Products' IronStar Raised Pavement Marker is available with multiple colors for any application.

Part Numbers		
Base Casting Only	664	—
Lens Color	Base and Reflector	Replacement Reflector Unit
2 Way Amber	6643M2A	3M-2A
2 Way White	6643M2W	3M-2W
2 Way White/Red	6643M2WR	3M-2WR
2 Way Amber/Red	6643M2AR	3M-2AR
2 Way Blue	6643M2B	3M-2B
1 Way Amber	6643M1A	3M-1A
1 Way White	6643M1W	3M-1W

Need More Information? Call Hallen Products' TODAY at 847/662-6868.



from HALLEN PRODUCTS

Model 664 Installation and Details

Low Profile, Two Way Snowplowable, Raised Pavement Marker.



Hallen Products, Ltd.
2500 Westward Dr., Unit #2
Spring Grove, Illinois 60081 USA

Phone: 815/675-3100
Fax: 815/675-3110
www.ironstar.com email: hallen@ais.net

GENERAL NOTES

1. Pavement must be cut to the dimensions as shown.
2. Minimum 65 Horsepower saw is recommended for making pavement cuts.
3. The saw is to be fitted with grouping of 18" diameter or 16" diameter saw blades with spacers as recommended by saw blade manufacturer.
4. Each pavement cut must be inspected prior to epoxy/marker installation per the following:
 - Each casting must be centered lengthwise and should have 1/8" side to side clearance after insertion in pavement cut.
 - All 4 leveling lugs must contact the pavement surface.
 - The extreme ends of all castings must be below pavement surface after insertion in pavement cut.
5. The pavement cut must be completely dry and free of dust, dirt or any other material that will interfere with the adhesive bond.
6. 2 component epoxy adhesive is to be used to fill the pavement cut to within 1/4" of top of pavement. Then place marker into the epoxy filled pavement cut—noting 4 tabs must be in contact with pavement surface, and epoxy should be level with pavement surface. Epoxy should be prevented from blocking the reflector lens.
7. Any epoxy inadvertently spilled/dripped on the active reflector face must be removed immediately.

Saw Cut Detail

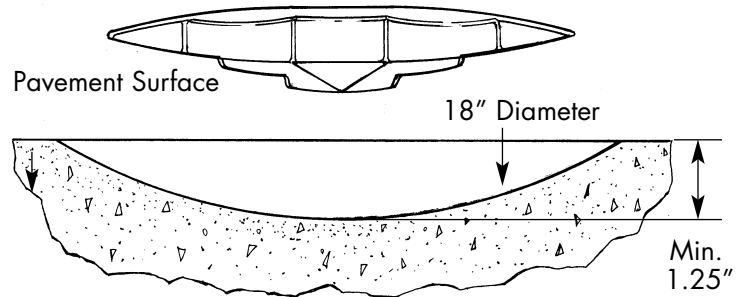

Section A-A

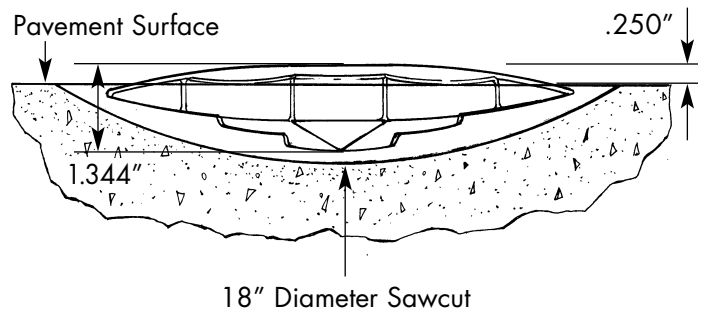

Note: All (4) Lugs Must Contact the Pavement

Section B-B

