

HALLEN
PRODUCTS
L I M I T E D

Model H960

Low Profile

**3M™ Snowplowable
Marker Series 190**

Hallen Products Snowplowable
Raised Pavement Marker.
Designed To Endure
The Rigors Of
The Road.

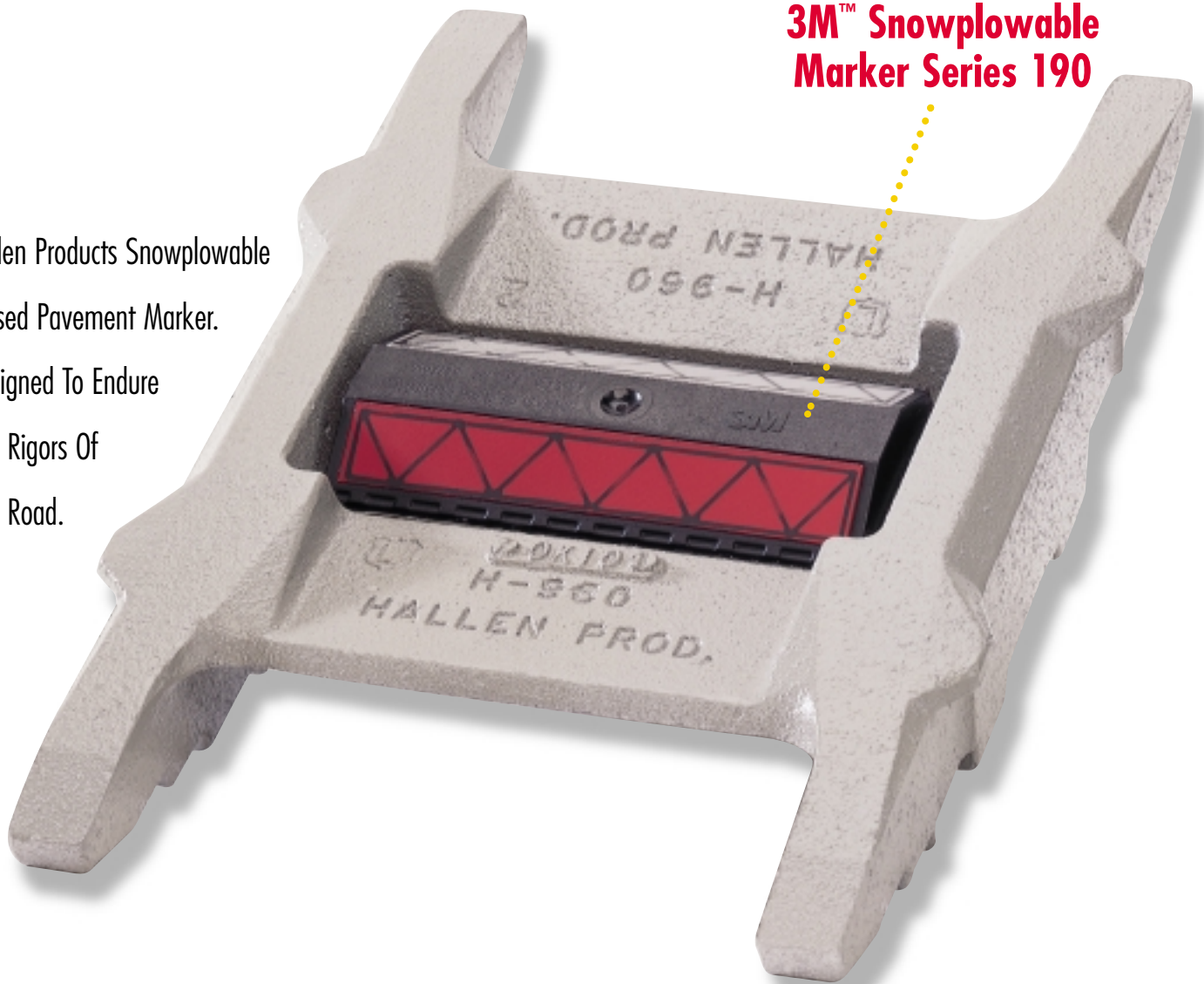

Designed For Safety. Engineered To Last.



Model H960 Installation and Details

Low Profile, Two Way Snowplowable, Raised Pavement Marker.

Hallen Products, Ltd.
2500 Westward Dr., Unit #2
Spring Grove, Illinois 60081 USA

Phone: 815/675-3100
Fax: 815/675-3110
email: hallen@ais.net

1. Pavement must be cut to the dimensions as shown.
2. Minimum 65 Horsepower saw is recommended for making pavement cuts.
3. The saw is to be fitted with grouping of 18" diameter saw blades with spacers, nested between 20" diameter saw blades with spacers as recommended by saw blade manufacturer.
4. Each pavement cut must be inspected prior to epoxy/marker installation per the following:
 - Each casting must be centered lengthwise and should have 1/8" side to side clearance after insertion in pavement cut.
 - All 4 leveling lugs must contact the pavement surface.
 - The extreme ends of all castings must be below pavement surface after insertion in pavement cut.
5. The pavement cut must be completely dry and free of dust, dirt or any other material that will interfere with the adhesive bond.
6. 2 component epoxy adhesive is to be used to fill the pavement cut to within 3/8" of top of pavement. Then place marker into the epoxy filled pavement cut—noting 4 tabs must be in contact with pavement surface, and epoxy should be level with pavement surface. Epoxy should be prevented from blocking the reflector lens.
7. Any epoxy inadvertently spilled/dripped on the active reflector face must be removed immediately.

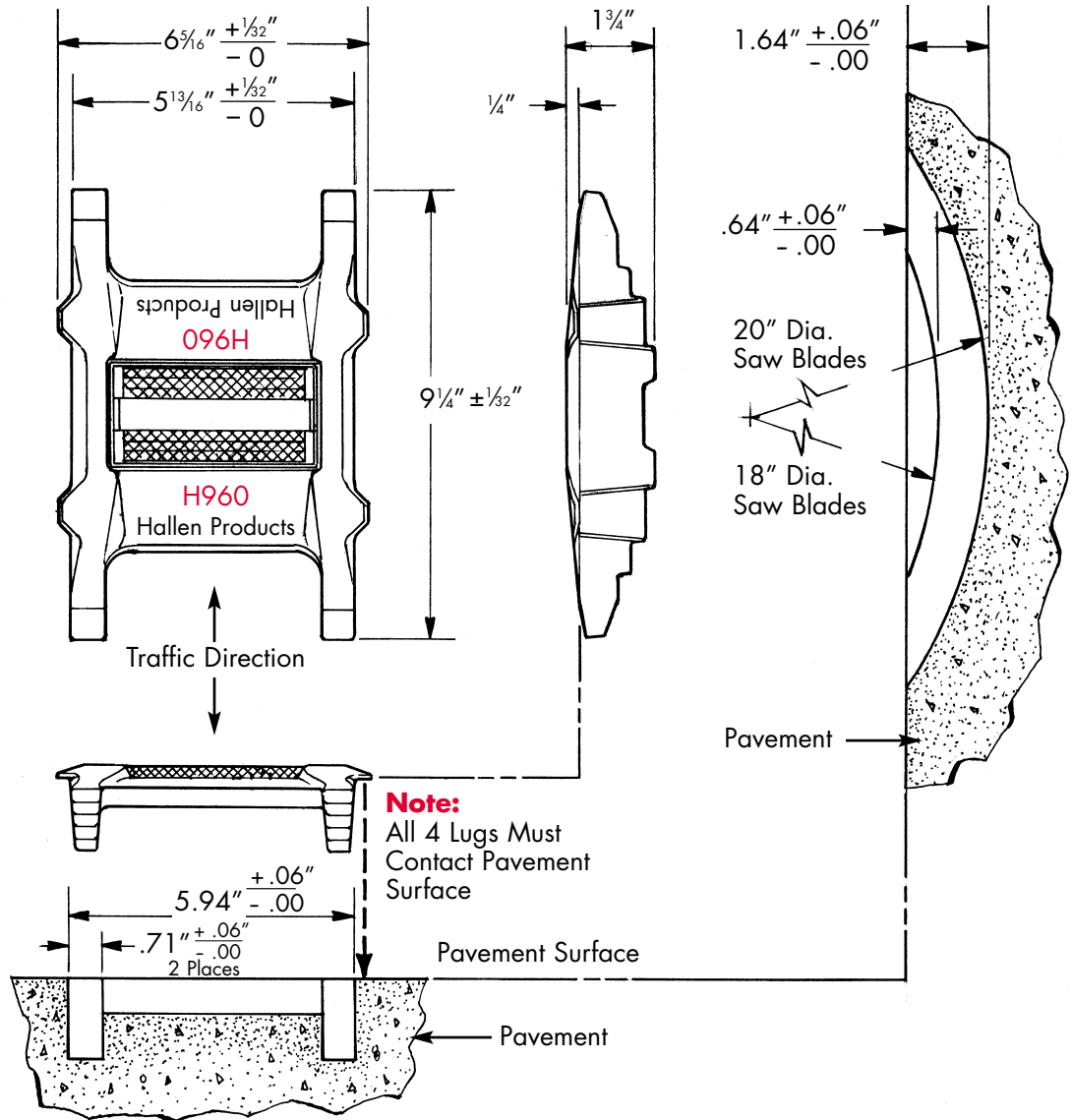

Multiple Colors For Multiple Applications

Lens Color	Part Numbers		Lens Color	Part Numbers	
	Base and Reflector	Replacement Reflector Unit		Base and Reflector	Replacement Reflector Unit
2 Way Amber	H9603M2A	3M-2A	1 Way Amber	H9603M1A	3M-1A
2 Way White	H9603M2W	3M-2W	1 Way White	H9603M1W	3M-1W
2 Way White/Red	H9603M2WR	3M-2WR			
2 Way Amber/Red	H9603M2AR	3M-2AR			
2 Way Blue	H9603M2B	3M-2B			
			Base Casting Only	H960	—